

Serie **T-HE2-HE3-DP**  
 Series

In generale dalla grandezza 71 ÷ 160 piedi riportati / In general from size 71 ÷ 160 removable feet

Tab. 45

**B3**

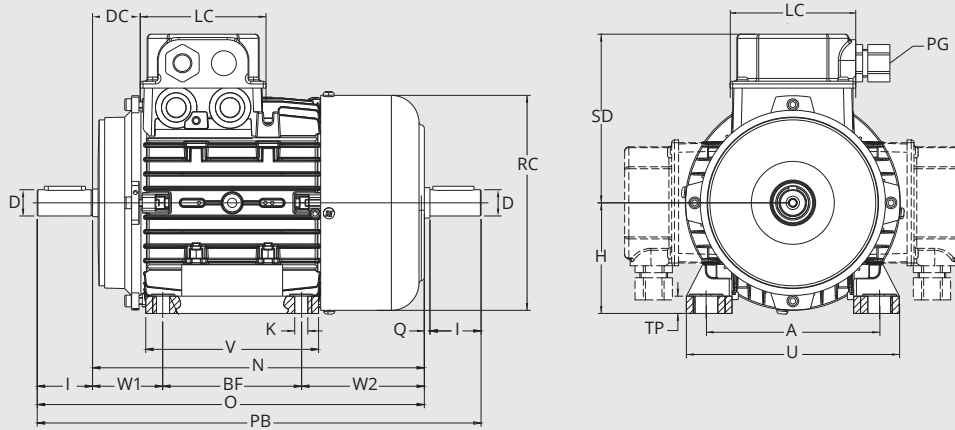

**B5**

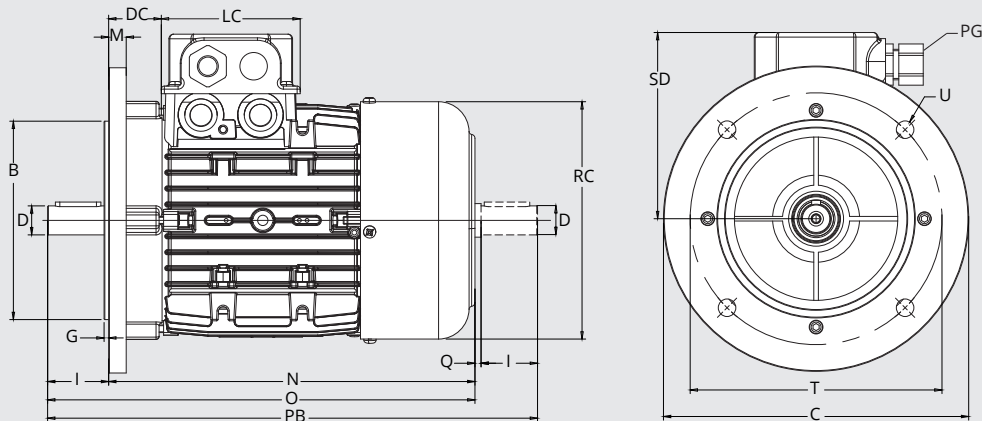

**B14**

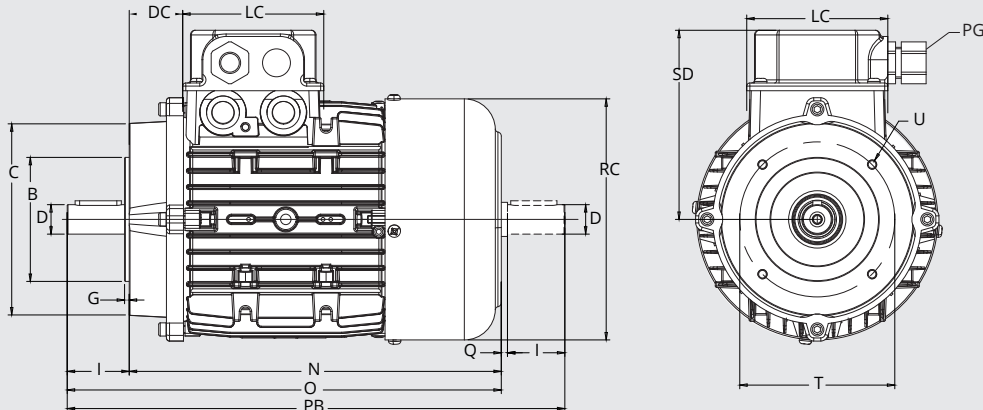

# Dimensioni motori trifase e doppia polarità

## Dimensions of three-phase and two speed motors

Tab. A

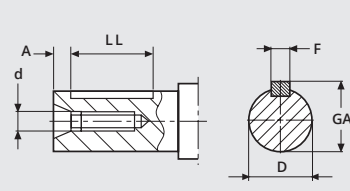

Grand. / Size	50	56	63	71	80	90	100	112	132	160
<b>F</b>	30	3	4	5	6	8	8	8	10	12
<b>D</b>	9	9	11	14	19	24	28	28	38	42
<b>GA</b>	10.2	10.2	12.5	16	21.5	27	31	31	41	45
<b>A</b>	2.5	2.5	4	5	5	5	5	5	10	5
<b>LL</b>	15	15	15	20	30	40	50	50	60	100
<b>d</b>	/	M4	M4	M5	M6	M8	M10	M10	M12	M16

Grand. Size	Dimensioni / Dimensions																B3			
	D	I	Q	A	BF	U*	V	K	TP	W1	W2	RC	H	SD	LC	DC	PG	N*	O*	PB*
<b>56</b>	9	20	3	90	71	108	90	6	10	36	59,5	110	56	95	75	24	M16	166,5	186,5	209,5
<b>63</b>	11	23	3	100	80	120	105	7	10	41	70	123	63	100	75	28	M16	188,5	211,5	237,5
<b>71</b>	14	30	3	112	90	136	108	8	11	48	82	137	71	109	75	36	M16	220	250	283
<b>80</b>	19	40	4	125	100	154	125	9	13/14	51	88	156	80	120	91	35	M20	240	280	324
<b>90S</b>	24	50	3	140	100	170	130	10	13/15	57,5	97,5	176	90	128	91	40	M20	255	305	358
<b>90L</b>	24	50	3	140	125	170	155	10	13/15	57,5	97,5	176	90	128	91	40	M20	280	330	383
<b>100</b>	28	60	5	160	140	192	175	13	15/16	63	114	194	100	140	91	45	M20	317	377	442
<b>112</b>	28	60	5	190	140	224	176	13	15	71	128	218	112	149	91	47	M20	339	399	464
<b>132S</b>	38	80	6	216	140	260	180	14	16/18	89,5	146	258	132	177	106	57	M32	375,5	455,5	541,5
<b>132M</b>	38	80	6	216	178	260	218	14	16/18	89,5	146	258	132	177	106	57	M32	413,5	493,5	579,5
<b>160M</b>	42	110	7	254	210	318	260	16	18	110	171	309	160	220	165	118	M32	491	601	718
<b>160L</b>	42	110	7	254	254	318	304	16	18	110	171	309	160	220	165	118	M32	535	645	762

Grand. Size	Dimensioni / Dimensions																B5		
	D	I	Q	B	C	G	M	T	U***	RC	SD	LC	DC	PG	N*	O*	PB*		
<b>56</b>	9	20	3	80	120	2,5	8,5	100	7	110	95	75	24	M16	166,5	186,5	209,5		
<b>63</b>	11	23	3	95	140	3	10	115	9,5	123	100	75	28	M16	188,5	211,5	237,5		
<b>71</b>	14	30	3	110	160	3	10	130	9,5	137	109	75	36	M16	220	250	283		
<b>80</b>	19	40	4	130	200	3,5	11	165	11,5	156	120	91	35	M20	240	280	324		
<b>90S</b>	24	50	3	130	200	3,5	10	165	11,5	176	128	91	40	M20	255	305	358		
<b>90L</b>	24	50	3	130	200	3,5	10	165	11,5	176	128	91	40	M20	280	330	383		
<b>100</b>	28	60	5	180	250	4	14	215	14	194	140	91	45	M20	317	377	442		
<b>112</b>	28	60	5	180	250	4	14	215	14	218	149	91	47	M20	339	399	464		
<b>132S</b>	38	80	6	230	300	4	20	265	14	258	177	106	57	M32	375,5	455,5	541,5		
<b>132M</b>	38	80	6	230	300	4	20	265	14	258	177	106	57	M32	413,5	493,5	579,5		
<b>160M</b>	42	110	7	250	350	5	20	300	18,5	309	220	165	118	M32	491	601	718		
<b>160L</b>	42	110	7	250	350	5	20	300	18,5	309	220	165	118	M32	535	645	762		

Grand. Size	Dimensioni / Dimensions																B14		
	D	I	Q	B	C**	G	T	U	RC	SD	LC	DC	PG	N*	O*	PB*			
<b>50B</b>	9	20	3	50	80	2,5	65	M5	98	100	64	23	M16	141	161	184			
<b>56</b>	9	20	3	50	80	2,5	65	M5	110	103	75	24	M16	166,5	186,5	209,5			
<b>63</b>	11	23	3	60	90	2,5	75	M5	123	112	75	28	M16	188,5	211,5	237,5			
<b>71</b>	14	30	3	70	105	3	85	M6	137	119	75	36	M16	220	250	283			
<b>80</b>	19	40	4	80	120	3	100	M6	156	139	91	35	M20	240	280	324			
<b>90S</b>	24	50	3	95	140	3	115	M8	176	148	91	40	M20	255	305	358			
<b>90L</b>	24	50	3	95	140	3	115	M8	176	148	91	40	M20	280	330	383			
<b>100</b>	28	60	5	110	160	4	130	M8	194	157	91	45	M20	317	377	442			
<b>112</b>	28	60	5	110	160	4	130	M8	218	170	91	47	M20	339	399	464			
<b>132S</b>	38	80	6	130	200	4	165	M10	258	190	106	57	M32	375,5	455,5	541,5			
<b>132M</b>	38	80	6	130	200	4	165	M10	258	190	106	57	M32	413,5	493,5	579,5			
<b>160M</b>	42	110	7	180	250	4	215	M12	309	246	165	118	M32	491	601	718			
<b>160L</b>	42	110	7	180	250	4	215	M12	309	246	165	118	M32	535	645	762			

\* motori 90LB, 90LBB e 132ML a 6 poli IE3, più lunghi di circa 50 mm / 90LB, 90LBB and 132ML 6 poles IE3 motors around 50 mm longer  
 \*\*\* ± 0,5 tolleranza / ± 0,5 tolerance  
 \*\* la quota C può subire variazioni, essendo grezza / C may vary since it is rough

Tutte le quote indicate sono in millimetri (mm) / All the values are expressed in millimeters (mm)